

<b>N° de fiche produit</b>	102FR
<b>Date de mise à jour</b>	04/2022
<b>Catégorie</b>	Moteurs électriques
<b>Sous-catégorie</b>	Moteurs électriques ATEX



## Moteurs électriques antidéflagrants

### Gamme YB3 : asynchrone triphasé

## 01. Introduction

La gamme YB3 est la gamme de nos moteurs antidéflagrants asynchrone triphasés.

Notre société fait fabriquer ces moteurs électriques avec les technologies les plus avancées tant pour le marché européen que pour le chinois.

Ces moteurs que nous concevons et développons répondent aux normes les plus exigeantes et répondent aux standards internationaux notamment concernant le niveau de valeur de conservation de l'énergie motrice 2 précisé dans la norme GB18613-2012 – sur les machines tournantes de petite et moyenne puissance, trois phases, asynchrone

Ces moteurs sont également conformes à différentes directives :

- GB3836.1 - 2010 et GB3836.2-2010 sur l'efficacité des moteurs électriques en environnements explosifs.
- IEC60079-1 – sur les équipements électriques antidéflagrants.
- Sur les structures de tests (50018) en environnement explosif avec équipement électrique standard.

Les moteurs sont de type EX. Les normes à l'épreuve des explosions sont Ex d I Mb, Ex d II AT4 T4 Gb, Ex d II B, Ex 2 d C T4 Gb, respectivement applicables à l'utilisation de l'équipement dans les exploitations minières ou dans les usines à environnement A grade II, IIB, IIC, classes de température pour T1 - T4 pour les sites avec mélange d'air explosif.

La puissance et les dimensions d'installation de nos moteurs sont conformes aux normes de la Commission électrotechnique internationale (IEC).



## 02. Description de l'appellation moteur

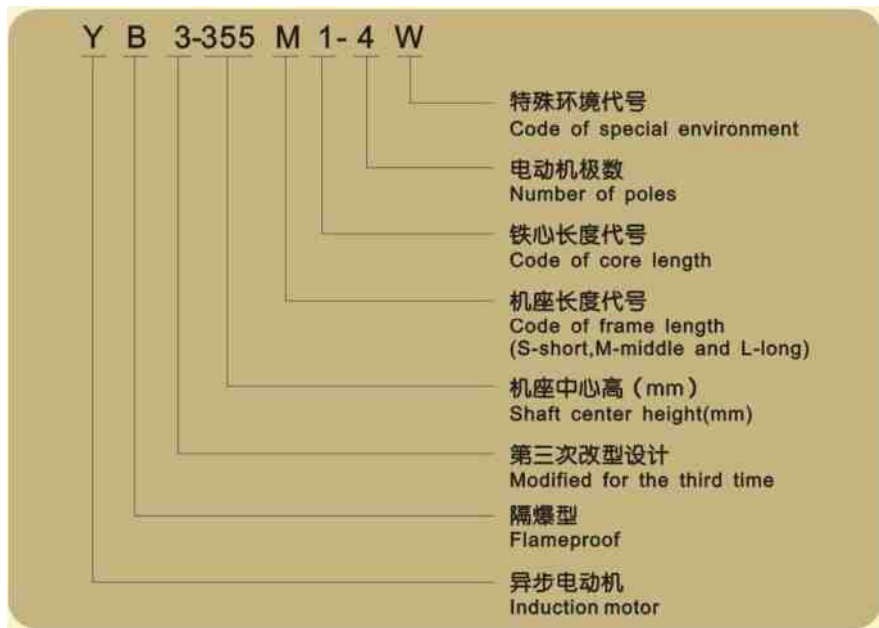

### **03. Conditions d'utilisation**

Température d'air ambiant : -15°C à 40°C

Altitude : 1000m maximum

Fréquence : 50HZ Pôles : 2 à 4

Voltage : 380V, 660V, 1140V, 380/660V, 660/1140V

Puissance : de 0,12 à 350KW

Condition de service : S1 Refroidissement : IC411 (air)

Protection IP54/55

Couleur : Bleu RAL5021 / Montage horizontal (autres montages possibles)



## 04. Caractéristiques techniques

电机型号 Motor Type	功率 Rate Power		电流 Current		额定转速 Rated Speed	功率因数 Power Factor	效率 Efficiency	堵转电流 额定电流	堵转转矩 额定转矩	最大转矩 额定转矩	转动惯量 Moment of inertia	重量 Weight
	kW	HP	380V A	400V A	r/min	cos φ	η %	Locked Current Rated Current	Locked Torque Rated Torque	Maximum Torque Rated Torque	J kg·m <sup>2</sup>	kg
YB3-63M1-2	0.18	0.24	0.52	0.49	2720	0.80	66.0	5.0	2.2	2.3	0.0001	14
YB3-63M2-2	0.25	0.33	0.69	0.66	2720	0.81	68.0	5.0	2.2	2.3	0.0002	15
YB3-63M1-4	0.12	0.16	0.44	0.41	1310	0.72	58.0	4.0	2.3	2.2	0.0003	15
YB3-63M2-4	0.18	0.24	0.59	0.56	1310	0.73	63.0	4.0	2.3	2.2	0.0004	16
YB3-71M1-2	0.37	0.5	0.99	0.94	2740	0.81	70.0	5.5	2.2	2.3	0.0003	16
YB3-71M2-2	0.55	0.75	1.38	1.31	2740	0.83	73.0	5.5	2.3	2.3	0.0005	17
YB3-71M1-4	0.25	0.33	0.78	0.74	1330	0.74	66.0	4.0	2.3	2.2	0.0006	17
YB3-71M2-4	0.37	0.5	1.09	1.03	1330	0.75	69.0	4.0	2.3	2.2	0.0008	18
YB3-71M1-6	0.18	0.24	0.67	0.63	850	0.66	62.0	4.0	1.9	2.1	0.0012	12
YB3-71M2-6	0.25	0.33	0.89	0.84	850	0.68	63.0	4.0	1.9	2.1	0.0013	13
YB3-80M1-2	0.75	1	1.77	1.68	2840	0.83	77.5	6.8	2.3	2.3	0.0010	24
YB3-80M2-2	1.1	1.5	2.43	2.31	2840	0.83	82.8	7.3	2.3	2.3	0.0014	25
YB3-80M1-4	0.55	0.75	1.38	1.31	1390	0.75	80.7	6.3	2.3	2.3	0.0020	24
YB3-80M2-4	0.75	1	1.85	1.75	1390	0.75	82.3	6.5	2.3	2.3	0.0026	27
YB3-80M1-6	0.37	0.5	1.27	1.21	885	0.70	63.0	4.0	1.9	2.1	0.0023	20
YB3-80M2-6	0.55	0.75	1.54	1.46	885	0.72	75.4	4.0	1.9	2.1	0.0031	25
YB3-80M1-8	0.18	0.24	0.86	0.82	645	0.61	52.0	3.3	1.8	1.9	0.0029	20
YB3-80M2-8	0.25	0.33	1.13	1.08	645	0.61	55.0	3.3	1.8	1.9	0.0035	22
YB3-90S-2	1.5	2	3.23	3.06	2840	0.84	84.1	7.6	2.3	2.3	0.0022	35
YB3-90L-2	2.2	3	4.59	4.36	2840	0.85	85.6	7.8	2.3	2.3	0.0028	38
YB3-90S-4	1.1	1.5	2.66	2.53	1390	0.75	83.8	6.6	2.3	2.3	0.0039	34
YB3-90L-4	1.5	2	3.58	3.40	1390	0.75	85.0	6.9	2.3	2.3	0.0052	38
YB3-90S-6	0.75	1	2.04	1.94	910	0.72	77.7	5.8	2.1	2.1	0.0051	39
YB3-90L-6	1.1	1.5	2.87	2.72	910	0.73	79.9	5.9	2.1	2.1	0.0074	41
YB3-90S-8	0.37	0.5	1.44	1.37	670	0.62	63.0	4.0	1.8	2	0.0046	28
YB3-90L-8	0.55	0.75	1.79	1.70	670	0.63	74.0	4.0	1.8	2	0.0061	30



电机型号 Motor Type	功率 Rate Power		电流 Current		额定转速 Rated Speed	功率因数 Power Factor	效率 Efficiency	堵转电流 额定电流	堵转转矩 额定转矩	最大转矩 额定转矩	转动惯量 Moment of inertia	重量 Weight
	kW	HP	380V A	400V A	r/min	cos φ	η %	Locked Current Rated Current	Locked Torque Rated Torque	Maximum Torque Rated Torque	J kg · m <sup>2</sup>	kg
YB3-100L-2	3	4	6.04	5.74	2860	0.87	86.7	8.1	2.3	2.3	0.004	44
YB3-100L1-4	2.2	3	4.78	4.54	1410	0.81	86.4	7.5	2.3	2.3	0.010	46
YB3-100L2-4	3	4	6.36	6.04	1410	0.82	87.4	7.6	2.3	2.3	0.012	51
YB3-100L-6	1.5	2	3.78	3.59	920	0.74	81.5	6.0	2.1	2.1	0.013	45
YB3-100L1-8	0.75	1	2.26	2.15	680	0.68	74.0	4.0	1.8	2.0	0.008	40
YB3-100L2-8	1.1	1.5	3.15	2.99	680	0.69	77.0	4.0	1.8	2.0	0.010	46
YB3-112M-2	4	5.5	7.88	7.49	2880	0.88	87.6	8.3	2.3	2.3	0.006	54
YB3-112M-4	4	5.5	8.39	7.97	1435	0.82	88.3	7.7	2.3	2.3	0.019	68
YB3-112M-6	2.2	3	5.42	5.15	935	0.74	83.4	6.0	2.1	2.1	0.019	57
YB3-112M-8	1.5	2	4.00	3.80	690	0.69	82.5	4.0	1.8	2.0	0.015	57
YB3-132S1-2	5.5	7.5	10.72	10.18	2900	0.88	88.6	8.0	2.2	2.3	0.013	81
YB3-132S2-2	7.5	10	14.31	13.59	2900	0.89	89.5	7.8	2.2	2.3	0.016	89
YB3-132S-4	5.5	7.5	11.42	10.85	1440	0.82	89.2	7.5	2.0	2.3	0.034	85
YB3-132M-4	7.5	10	15.24	14.48	1440	0.83	90.1	7.4	2.0	2.3	0.045	105
YB3-132S-6	3	4	7.26	6.89	960	0.74	84.9	6.2	2.0	2.1	0.036	84
YB3-132M1-6	4	5.5	9.54	9.06	960	0.74	86.1	6.8	2.0	2.1	0.048	92
YB3-132M2-6	5.5	7.5	12.75	12.11	960	0.75	87.4	7.1	2.0	2.1	0.063	104
YB3-132S-8	2.2	3	5.45	5.18	705	0.73	84.0	5.5	1.8	2.2	0.031	83
YB3-132M-8	3	4	7.30	6.94	705	0.73	85.5	5.5	1.8	2.2	0.043	95
YB3-160M1-2	11	15	20.75	19.71	2930	0.89	90.5	7.9	2.2	2.3	0.048	142
YB3-160M2-2	15	20	28.05	26.65	2930	0.89	91.3	8.0	2.2	2.3	0.060	152
YB3-160L-2	18.5	25	34.40	32.68	2930	0.89	91.8	8.1	2.2	2.3	0.071	169
YB3-160M-4	11	15	21.61	20.53	1460	0.85	91.0	7.5	2.2	2.3	0.095	150
YB3-160L-4	15	20	28.87	27.42	1460	0.86	91.8	7.5	2.2	2.3	0.121	171
YB3-160M-6	7.5	10	16.42	15.59	970	0.78	89.0	6.7	2.1	2.1	0.116	171
YB3-160L-6	11	15	23.51	22.33	970	0.79	90.0	6.9	2.1	2.1	0.153	180

电机型号 Motor Type	功率 Rate Power		电流 Current		额定转速 Rated Speed	功率因数 Power Factor	效率 Efficiency	堵转电流 额定电流	堵转转矩 额定转矩	最大转矩 额定转矩	转动惯量 Moment of inertia	重量 Weight
	kW	HP	380V A	400V A								
YB3-160M1-8	4	5.5	9.74	9.25	720	0.73	85.5	6.0	1.9	2.2	0.064	158
YB3-160M2-8	5.5	7.5	13.03	12.38	720	0.75	85.5	6.0	1.9	2.2	0.090	180
YB3-160L-8	7.5	10	16.94	16.10	720	0.76	88.5	6.0	1.9	2.2	0.127	181
YB3-180M-2	22	30	40.74	38.70	2940	0.89	92.2	8.2	2.2	2.3	0.111	227
YB3-180M-4	18.5	25	35.45	33.68	1470	0.86	92.2	7.7	2.2	2.3	0.173	211
YB3-180L-4	22	30	41.97	39.88	1470	0.86	92.6	7.8	2.2	2.3	0.207	224
YB3-180L-6	15	20	30.92	29.37	970	0.81	91.0	7.2	2.0	2.1	0.258	230
YB3-180L-8	11	15	24.85	23.61	730	0.76	88.5	6.0	1.9	2.2	0.214	228
YB3-200L1-2	30	40	55.13	52.37	2950	0.89	92.9	7.5	2.2	2.3	0.166	265
YB3-200L2-2	37	50	67.70	64.32	2950	0.89	93.3	7.5	2.2	2.3	0.195	275
YB3-200L-4	30	40	56.87	54.03	1470	0.86	93.2	7.2	2.2	2.3	0.323	290
YB3-200L1-6	18.5	25	37.93	36.03	980	0.81	91.5	7.2	2.1	2.1	0.379	309
YB3-200L2-6	22	30	44.31	42.09	980	0.82	92.0	7.3	2.1	2.1	0.449	320
YB3-200L-8	15	20	33.51	31.83	730	0.76	89.5	6.5	2.0	2.2	0.359	335
YB3-225M-2	45	60	81.99	77.89	2960	0.89	93.7	7.6	2.2	2.3	0.264	340
YB3-225S-4	37	50	69.84	66.35	1475	0.86	93.6	7.3	2.2	2.3	0.547	346
YB3-225M-4	45	60	84.67	80.43	1475	0.86	93.9	7.4	2.2	2.3	0.623	358
YB3-225M-6	30	40	60.84	57.79	980	0.81	92.5	7.1	2.0	2.1	0.619	364
YB3-225S-8	18.5	25	40.26	38.25	730	0.78	89.5	6.5	2.0	2.2	0.554	371
YB3-225M-8	22	30	47.09	44.74	730	0.78	91.0	6.5	2.0	2.2	0.651	398
YB3-250M-2	55	75	99.89	94.89	2965	0.89	94.0	7.6	2.2	2.3	0.383	477
YB3-250M-4	55	75	103.2	98.00	1480	0.86	94.2	7.4	2.2	2.3	0.773	492
YB3-250M-6	37	50	71.96	68.36	980	0.84	93.0	7.1	2.1	2.1	0.988	535
YB3-250M-8	30	40	63.40	60.23	735	0.79	91.0	6.5	1.9	2.0	0.988	522
YB3-280S-2	75	100	135.3	128.6	2970	0.89	94.6	6.9	2.0	2.3	0.677	655
YB3-280M-2	90	125	161.7	153.6	2970	0.89	95.0	7.0	2.0	2.3	0.794	733

电机型号 Motor Type	功率 Rate Power		电流 Current		额定转速 Rated Speed	功率因数 Power Factor	效率 Efficiency	堵转电流 额定电流	堵转转矩 额定转矩	最大转矩 额定转矩	转动惯量 Moment of inertia	重量 Weight
	kW	HP	380V A	400V A	r/min	cos φ	η %	Locked Current Rated Current	Locked Torque Rated Torque	Maximum Torque Rated Torque	J kg·m <sup>2</sup>	kg
YB3-280S-4	75	100	136.7	129.9	1480	0.88	94.7	6.7	2.2	2.3	1.601	670
YB3-280M-4	90	125	163.6	155.4	1480	0.88	95.0	6.9	2.2	2.3	1.944	743
YB3-280S-6	45	60	85.0	80.8	980	0.86	93.5	7.2	2.1	2.0	1.709	643
YB3-280M-6	55	75	103.6	98.4	980	0.86	93.8	7.2	2.1	2.0	2.107	735
YB3-280S-8	37	50	77.6	73.7	735	0.79	91.7	6.0	1.8	2.0	1.709	626
YB3-280M-8	45	60	94.4	89.7	735	0.79	91.7	6.0	1.8	2.0	1.988	722
YB3-315S-2	110	150	195.5	185.7	2975	0.90	95.0	7.1	2.0	2.2	1.539	1140
YB3-315M-2	132	180	233.6	221.9	2975	0.90	95.4	7.1	2.0	2.2	1.735	1170
YB3-315L1-2	160	220	280.0	266.0	2975	0.91	95.4	7.1	2.0	2.2	1.986	1385
YB3-315L2-2	200	270	350.0	332.5	2975	0.91	95.4	7.1	2.0	2.2	2.210	1610
YB3-315S-4	110	150	199.1	189.1	1480	0.88	95.4	6.9	2.2	2.2	3.228	986
YB3-315M-4	132	180	238.9	227.0	1480	0.88	95.4	6.9	2.2	2.2	3.599	1070
YB3-315L1-4	160	220	286.3	272.0	1480	0.89	95.4	6.9	2.2	2.2	4.181	1350
YB3-315L2-4	200	270	357.9	340.0	1480	0.89	95.4	6.9	2.2	2.2	4.975	1572
YB3-315S-6	75	100	142.3	135.2	985	0.85	94.2	6.7	2.0	2.0	3.929	1095
YB3-315M-6	90	125	172.3	163.7	985	0.84	94.5	6.7	2.0	2.0	4.280	1153
YB3-315L1-6	110	150	207.0	196.6	985	0.85	95.0	6.7	2.0	2.0	5.473	1330
YB3-315L2-6	132	180	245.5	233.2	985	0.86	95.0	6.7	2.0	2.0	6.596	1485
YB3-315S-8	55	75	110.9	105.4	735	0.81	93.0	6.5	1.8	2.0	3.960	955
YB3-315M-8	75	100	151.3	143.7	735	0.81	93.0	6.5	1.8	2.0	5.280	1160
YB3-315L1-8	90	125	180.4	171.3	735	0.81	93.6	6.5	1.8	2.0	6.270	1238
YB3-315L2-8	110	150	217.8	206.9	735	0.82	93.6	6.5	1.8	2.0	7.425	1362
YB3-315S-10	45	60	99.6	94.7	590	0.75	91.5	6.0	1.5	2.0	3.877	1042
YB3-315M-10	55	75	121.1	115.1	590	0.75	92.0	6.0	1.5	2.0	4.785	1157
YB3-315L1-10	75	100	162.1	154.0	590	0.76	92.5	6.0	1.5	2.0	6.187	1310
YB3-315L2-10	90	125	191.0	181.4	590	0.77	93.0	6.0	1.5	2.0	7.260	1385



电机型号 Motor Type	功率 Rate Power		电流 Current		额定转速 Rated Speed	功率因数 Power Factor	效率 Efficiency	堵转电流 额定电流	堵转转矩 额定转矩	最大转矩 额定转矩	转动惯量 Moment of inertia	重量 Weight
	kW	HP	380V A	400V A	r/min	cos φ	η %	Locked Current Rated Current	Locked Torque Rated Torque	Maximum Torque Rated Torque	J kg·m <sup>2</sup>	kg
YB3-355S1-2	185	250	323.8	307.6	2980	0.91	95.4	7.1	2.0	2.2	2.395	1650
YB3-355S2-2	200	270	350.0	332.5	2980	0.91	95.4	7.1	2.0	2.2	2.748	1650
YB3-355M1-2	220	165	385.0	365.8	2980	0.91	95.4	7.1	2.0	2.2	2.827	1680
YB3-355M2-2	250	340	435.7	413.9	2980	0.91	95.8	7.1	2.0	2.2	3.259	1720
YB3-355L1-2	280	380	488.0	463.6	2980	0.91	95.8	7.1	2.0	2.2	3.337	1780
YB3-355L2-2	315	430	549.0	521.5	2980	0.91	95.8	7.1	2.0	2.2	4.005	1850
YB3-355S1-4	185	250	331.1	314.5	1490	0.89	95.4	6.9	2.2	2.2	6.111	1620
YB3-355S2-4	200	270	357.9	340.0	1490	0.89	95.4	6.9	2.2	2.2	6.650	1620
YB3-355M1-4	220	165	389.3	369.8	1490	0.90	95.4	6.9	2.2	2.2	7.279	1690
YB3-355M2-4	250	340	440.6	418.5	1490	0.90	95.8	6.9	2.2	2.2	8.088	1750
YB3-355L1-4	280	380	493.4	468.8	1490	0.90	95.8	6.9	2.2	2.2	8.987	1800
YB3-355L2-4	315	430	555.1	527.3	1490	0.90	95.8	6.9	2.2	2.2	10.245	1850
YB3-355S-6	160	220	294.1	279.4	990	0.87	95.0	6.7	2.0	2.0	9.189	1610
YB3-355M1-6	185	250	340.1	323.1	990	0.87	95.0	6.7	2.0	2.0	10.097	1750
YB3-355M2-6	200	270	367.7	349.3	990	0.87	95.0	6.7	2.0	2.0	11.344	1750
YB3-355L1-6	220	165	404.4	384.2	990	0.87	95.0	6.7	2.0	2.0	12.479	1800
YB3-355L2-6	250	340	459.6	436.6	740	0.87	95.0	6.7	2.0	2.0	18.084	1850
YB3-355S-8	132	180	259.9	246.9	740	0.82	94.1	6.5	1.8	2.0	11.428	1620
YB3-355M-8	160	220	315.1	299.3	740	0.82	94.1	6.5	1.8	2.0	13.936	1710
YB3-355L1-8	185	250	364.3	346.1	740	0.82	94.1	6.5	1.8	2.0	16.166	1900
YB3-355L2-8	200	270	387.4	368.1	590	0.83	94.5	6.5	1.8	2.0	18.117	2000
YB3-355S-10	90	125	191.0	181.4	590	0.77	93.0	6.0	1.5	2.0	9.354	1450
YB3-355M1-10	110	150	229.9	218.4	590	0.78	93.2	5.5	1.3	2.0	11.448	1500
YB3-355M2-10	132	180	275.0	261.3	590	0.78	93.5	5.5	1.3	2.0	13.961	1600
YB3-355L1-10	160	220	333.3	316.7	590	0.78	93.5	5.5	1.3	2.0	17.312	1700
YB3-355L2-10	185	250	385.4	366.1	590	0.78	93.5	5.5	1.3	2.0	19.965	1800

型号 Type	功率 kW	额定电流 Current A	转速 r/min	效率 Eff %	功率因数 Power Factor	堵转转矩 额定转矩 Locked Rotor Torque Rated Torque	堵转电流 额定电流 Locked Rotor Current Rated Current	最大转矩 额定转矩 Breakdown Roque Rated Torque
同步转速 3000r/min								
YB3-400-1-2	355	614	2980	95.5	0.92	1.6	7.0	2.0
YB3-400-2-2	400	695	2980	95.6	0.915	1.6	7.0	2.0
YB3-400-3-2	450	782	2980	95.6	0.915	1.6	7.0	2.0
YB3-400-4-2	500	868	2980	95.6	0.915	1.6	7.0	2.0
YB3-400-5-2	630	1094	2980	95.6	0.915	1.6	7.0	2.0
同步转速 1500r/min								
YB3-400-1-4	355	628	1490	95.5	0.90	1.65	6.9	2.4
YB3-400-2-4	400	706	1490	95.6	0.90	1.65	6.9	2.4
YB3-400-3-4	450	790	1490	95.6	0.905	1.7	6.9	2.4
YB3-400-4-4	500	878	1490	95.6	0.905	1.7	6.9	2.4
YB3-400-5-4	560	983	1490	95.6	0.905	1.7	6.9	2.4
YB3-400-6-4	630	1106	1490	95.6	0.905	1.7	6.9	2.4
同步转速 1000r/min								
YB3-400-1-6	280	521	990	94.9	0.86	1.9	7.0	2.3
YB3-400-2-6	315	586	990	95.0	0.86	1.9	7.0	2.3
YB3-400-3-6	355	660	990	95.0	0.86	1.9	7.0	2.3
YB3-400-4-6	400	740	990	95.0	0.865	1.9	7.0	2.3
YB3-400-5-6	450	832	990	95.0	0.865	1.9	7.0	2.3
YB3-400-6-6	500	924	990	95.0	0.865	1.6	7.0	2.3
同步转速750r/min								
YB3-400-1-8	220	431	740	94.6	0.82	1.8	6.8	2.0
YB3-400-2-8	250	490	740	94.6	0.82	1.8	6.8	2.0
YB3-400-3-8	280	548	740	94.6	0.82	1.8	6.8	2.3
YB3-400-4-8	315	613	740	94.6	0.825	1.8	6.8	2.3
YB3-400-5-8	355	691	740	94.6	0.825	1.8	6.8	2.3
YB3-400-6-8	400	779	740	94.6	0.825	1.6	6.8	2.3
同步转速 600r/min								
YB3-400-1-10	200	427	590	93.7	0.76	1.6	6.0	1.8
YB3-400-2-10	220	469	590	93.7	0.76	1.6	6.0	1.9
YB3-400-3-10	250	533	590	93.7	0.76	1.6	6.0	1.9
YB3-400-4-10	280	597	590	93.8	0.76	1.6	6.0	1.9
YB3-400-5-10	315	663	590	93.8	0.77	1.6	6.5	1.9
YB3-400-6-10	355	747	590	93.8	0.77	1.6	6.5	1.9
同步转速 500r/min								
YB3-400-3-12	185	488	495	92.9	0.62	1.6	5.5	2.0
YB3-400-4-12	200	528	495	92.9	0.62	1.6	5.5	2.0
YB3-400-5-12	220	562	495	93.0	0.64	1.6	5.5	2.0
YB3-400-6-12	250	638	495	93.0	0.64	1.6	6.0	2.0
YB3-400-7-12	280	715	495	93.0	0.64	1.6	6.0	2.0
YB3-400-8-12	355	906	495	93.0	0.64	1.6	6.0	2.0

## 05. Montage et dimensions

1 - B3 : With foot mounted and flangeless (1)

机座号 Frame Size	极数 Poles	安装尺寸 Mounting Dimensions (mm)										外形尺寸 Outline Dimensions (mm)									
		A	B	C	D	E	F	G	H	K	AA	AB	AC	AD	BD	HA	HD	BB	LD	L	
63M	2~4	100	80	40	11	23	4	8.5	63	7	25	130	150	170	15	8	230	110	78	250	
71M	2~6	112	90	45	14	30	5	11	71	7	28	140	155	170	10	8	250	114	93	280	
80M	2~8	125	100	50	19	40	6	15.5	80	10	34	165	170	175	14	10	320	130	101	320	
90S	2~8	140	100	56	24	50	8	20	90	10	36	180	190	175	15	14	350	130	106	370	
90L	2~8	140	125	56	24	50	8	20	90	10	36	180	190	175	15	14	350	155	106	395	
100L	2~8	160	140	63	28	60	8	24	100	12	43	200	215	175	18	14	400	176	102	450	
112M	2~8	190	140	70	28	60	8	24	112	12	50	245	230	185	20	16	420	180	123	510	
132S	2~8	216	140	89	38	80	10	33	132	12	60	280	270	185	28	18	450	190	123	540	
132M	2~8	216	178	89	38	80	10	33	132	12	60	280	270	185	28	18	450	230	123	590	
160M	2~8	254	210	108	42	110	12	37	160	14.5	70	330	325	205	24	25	520	252	162	690	
160L	2~8	254	254	108	42	110	12	37	160	14.5	70	330	325	205	24	25	520	302	162	730	
180M	2~4	279	241	121	48	110	14	42.5	180	14.5	70	355	360	205	35	22	550	311	169	780	
180L	4~8	279	279	121	48	110	14	42.5	180	14.5	70	355	360	205	35	22	550	349	169	800	
200L	2~8	318	305	133	55	110	16	49	200	18.5	70	390	400	235	32	25	580	366	181	840	
225S	4~8	356	286	149	60	140	18	53	225	18.5	75	435	450	235	35	28	630	355	206	890	
225M	2	356	311	149	55	110	16	49	225	18.5	75	435	450	235	35	28	630	380	206	890	
250M	4~8	356	311	149	60	140	18	53	225	18.5	75	435	450	235	35	28	630	380	206	920	
250M	2	406	349	168	60	140	18	53	250	24	80	490	500	270	38	30	730	420	230	965	
280S	4~8	406	349	168	65	140	18	58	250	24	80	490	500	270	38	30	730	420	230	965	
280S	2	457	368	190	65	140	18	58	280	24	85	545	560	270	45	35	800	438	228	1040	
280S	4~8	457	368	190	75	140	20	67.5	280	24	85	545	560	270	45	35	800	438	228	1040	
280M	2	457	419	190	65	140	18	58	280	24	85	545	560	270	45	35	800	493	228	1090	
280M	4~8	457	419	190	75	140	20	67.5	280	24	85	545	560	270	45	35	800	493	228	1090	
315S	2	508	406	216	65	140	18	58	315	28	120	640	630	360	72	45	1000	550	297	1185	
315S	4~10	508	406	216	80	170	22	71	315	28	120	640	630	360	72	45	1000	550	297	1260	
315M	2	508	457	216	65	140	18	58	315	28	120	640	630	360	72	45	1000	680	297	1305	
315M	4~10	508	457	216	80	170	22	71	315	28	120	640	630	360	72	45	1000	680	297	1380	



1 - B3 : With foot mounted and flangeless (2)

机座号 Frame Size	极数 Poles	安装尺寸 Mounting Dimensions (mm)										外形尺寸 Outline Dimensions (mm)									
		A	B	C	D	E	F	G	H	K	AA	AB	AC	AD	BD	HA	HD	BB	LD	L	
315L	2	508	508	216	65	140	18	58	315	28	120	640	630	360	72	45	1000	680	297	1305	
	4~10	508	508	216	80	170	22	71	315	28	120	640	630	360	72	45	1000	680	297	1380	
355S	2	610	500	254	75	140	20	67.5	355	28	116	740	720	360	68	52	1080	636	316	1415	
	4~10	610	500	254	95	170	25	86	355	28	116	740	720	360	68	52	1080	636	316	1485	
355M	2	610	560	254	75	140	20	67.5	355	28	116	740	720	360	68	52	1080	696	316	1495	
	4~10	610	560	254	95	170	25	86	355	28	116	740	720	360	68	52	1080	696	316	1565	
355L	2	610	630	254	75	140	20	67.5	355	28	116	740	720	360	68	52	1080	766	316	1645	
	4~10	610	630	254	95	170	25	86	355	28	116	740	720	360	68	52	1080	766	316	1675	

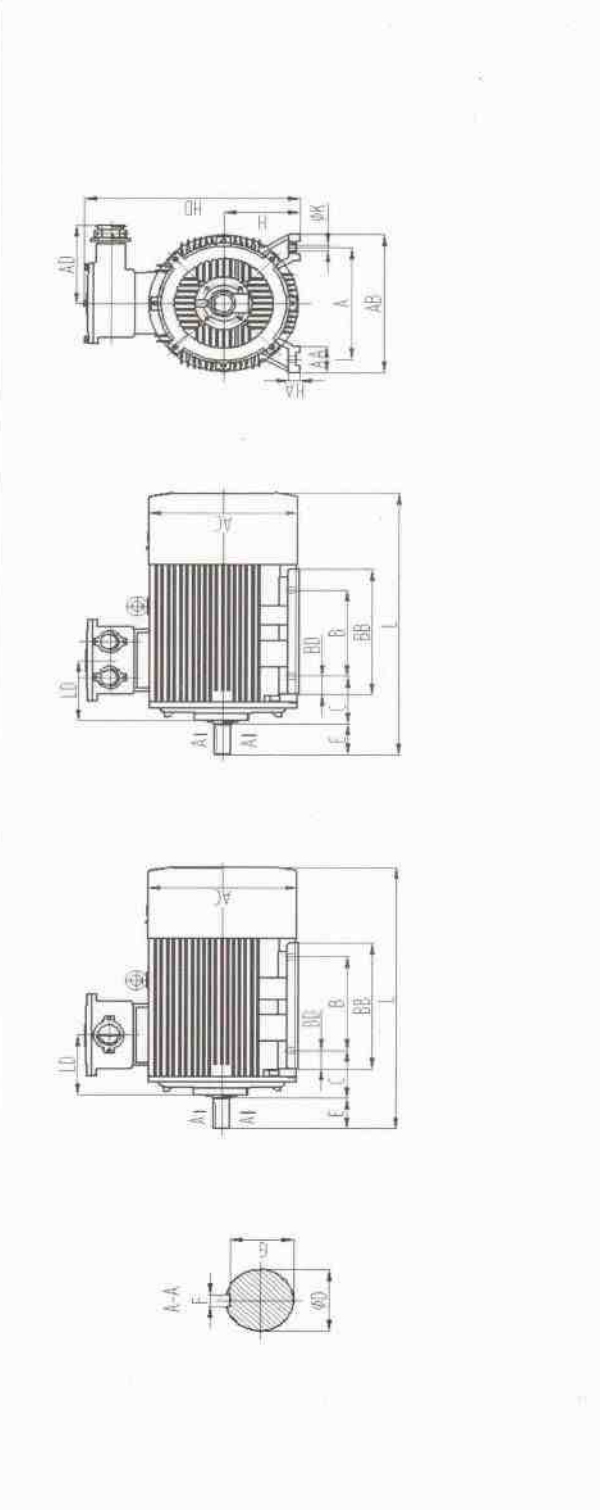



## 2 - B35 : With both foot and flange mounted

机座号 Frame Size	极数 Poles	安装尺寸 Mounting Dimensions (mm)																外形尺寸 Outline Dimensions (mm)									
		A	B	C	D	E	F	G	H	K	M	N	P	R	S	T	Φ	AA	AB	AC	BB	BD	HA	HD	LA	LD	L
80M	2~8	125	100	50	19	40	6	15.5	80	10	165	130	200	0	4-Φ12	4	45	34	165	170	130	14	10	320	12	101	320
90S	2~8	140	100	56	24	50	8	20	90	10	165	130	200	0	4-Φ12	4	45	36	180	190	130	15	14	350	12	106	370
90L	2~8	140	125	56	24	50	8	20	90	10	165	130	200	0	4-Φ12	4	45	36	180	190	155	15	14	350	12	106	395
100L	2~8	160	140	63	28	60	8	24	100	12	215	180	250	0	4-Φ14.5	4	45	43	200	215	176	18	14	400	12	102	450
112M	2~8	190	140	70	28	60	8	24	112	12	215	180	250	0	4-Φ14.5	4	45	50	245	230	180	20	16	420	14	123	510
132S	2~8	216	140	89	38	80	10	33	132	12	265	230	300	0	4-Φ14.5	4	45	60	280	270	190	28	18	450	15	123	540
132M	2~8	216	178	89	38	80	10	33	132	12	265	230	300	0	4-Φ14.5	4	45	60	280	270	230	28	18	450	15	123	590
160M	2~8	254	210	108	42	110	12	37	160	14.5	300	250	350	0	4-Φ18.5	5	45	70	330	325	252	24	25	520	15	162	690
160L	2~8	254	254	108	42	110	12	37	160	14.5	300	250	350	0	4-Φ18.5	5	45	70	330	325	302	24	25	520	15	162	730
180M	2~4	279	241	121	48	110	14	42.5	180	14.5	300	250	350	0	4-Φ18.5	5	45	70	355	360	311	35	22	550	16	169	780
180L	4~8	279	279	121	48	110	14	42.5	180	14.5	300	250	350	0	4-Φ18.5	5	45	70	355	360	349	35	22	550	16	169	800
200L	2~8	318	305	133	55	110	16	49	200	18.5	350	300	400	0	4-Φ18.5	5	45	70	390	400	366	32	25	580	20	181	840
225S	4~8	356	286	149	60	140	18	53	225	18.5	400	350	450	0	8-Φ18.5	5	22.5	75	435	450	355	35	28	630	20	206	890
225M	2	356	311	149	55	110	16	49	225	18.5	400	350	450	0	8-Φ18.5	5	22.5	75	435	450	380	35	28	630	20	206	890
	4~8	356	311	149	60	140	18	53	225	18.5	400	350	450	0	8-Φ18.5	5	22.5	75	435	450	380	35	28	630	20	206	920
250M	2	406	349	168	60	140	18	53	250	24	500	450	550	0	8-Φ18.5	5	22.5	80	490	500	420	38	30	730	22	230	965
	4~8	406	349	168	65	140	18	58	250	24	500	450	550	0	8-Φ18.5	5	22.5	80	490	500	420	38	30	730	22	230	965
280S	2	457	368	190	65	140	18	58	280	24	500	450	550	0	8-Φ18.5	5	22.5	85	545	560	438	45	35	800	22	228	1040
	4~8	457	368	190	75	140	20	67.5	280	24	500	450	550	0	8-Φ18.5	5	22.5	85	545	560	438	45	35	800	22	228	1040
280M	2	457	419	190	65	110	18	58	280	24	500	450	550	0	8-Φ18.5	5	22.5	85	545	560	493	45	35	800	22	228	1090
	4~8	457	419	190	75	140	20	67.5	280	24	500	450	550	0	8-Φ18.5	5	22.5	85	545	560	493	45	35	800	22	228	1090
315S	2	508	406	216	65	140	18	58	315	28	600	550	660	0	8-Φ24	6	22.5	120	640	630	550	72	45	1000	30	297	1185
	4~10	508	406	216	80	170	22	71	315	28	600	550	660	0	8-Φ24	6	22.5	120	640	630	550	72	45	1000	30	297	1260
315M	2	508	457	216	65	140	18	58	315	28	600	550	660	0	8-Φ24	6	22.5	120	640	630	680	72	45	1000	30	297	1305
	4~10	508	457	216	80	170	22	71	315	28	600	550	660	0	8-Φ24	6	22.5	120	640	630	680	72	45	1000	30	297	1380
315L	2	508	508	216	65	140	18	58	315	28	600	550	660	0	8-Φ24	6	22.5	120	640	630	680	72	45	1000	30	297	1305
	4~10	508	508	216	80	170	22	71	315	28	600	550	660	0	8-Φ24	6	22.5	120	640	630	680	72	45	1000	30	297	1380
355S	2	610	500	254	75	140	20	67.5	355	28	740	680	800	0	8-Φ24	6	22.5	116	740	720	636	68	52	1080	25	316	1415
	4~10	610	500	254	95	170	25	86	355	28	740	680	800	0	8-Φ24	6	22.5	116	740	720	636	68	52	1080	25	316	1485
355M	2	610	560	254	75	140	20	67.5	355	28	740	680	800	0	8-Φ24	6	22.5	116	740	720	696	68	52	1080	25	316	1495
	4~10	610	560	254	95	170	25	86	355	28	740	680	800	0	8-Φ24	6	22.5	116	740	720	696	68	52	1080	25	316	1565
355L	2	610	630	254	75	140	20	67.5	355	28	740	680	800	0	8-Φ24	6	22.5	116	740	720	766	68	52	1080	25	316	1645
	4~10	610	630	254	95	170	25	86	355	28	740	680	800	0	8-Φ24	6	22.5	116	740	720	766	68	52	1080	25	316	1675

注: R为凸缘配合面到轴伸肩的距离 R=distance from flange to shaft shoulder.

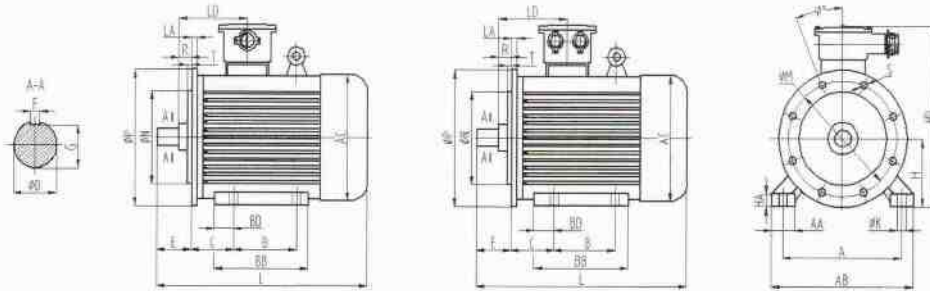

### 3 - B5 : With flange mounted and footless

机座号 Frame Size	极数 Poles	安装尺寸 Mounting Dimensions (mm)											外形尺寸 Outline Dimensions (mm)				
		D	E	F	G	M	N	P	R	S	T	Φ	AC	HD	LA	LD	L
63M	2~4	11	23	4	8.5	115	95	140	0	4-Φ10	3	45	150	230	12	78	250
71M	2~6	14	30	5	11	130	110	160	0	4-Φ10	3	45	155	250	12	93	280
80M	2~8	19	40	6	15.5	165	130	200	0	4-Φ12	3.5	45	170	320	12	101	320
90S	2~8	24	50	8	20	165	130	200	0	4-Φ12	3.5	45	190	350	12	106	370
90L	2~8	24	50	8	20	165	130	200	0	4-Φ12	3.5	45	190	350	12	106	395
100L	2~8	28	60	8	24	215	180	250	0	4-Φ14.5	4	45	215	400	12	102	450
112M	2~8	28	60	8	24	215	180	250	0	4-Φ14.5	4	45	230	420	14	123	510
132S	2~8	38	80	10	33	265	230	300	0	4-Φ14.5	4	45	270	450	15	123	540
132M	2~8	38	80	10	33	265	230	300	0	4-Φ14.5	4	45	270	450	15	123	590
160M	2~8	42	110	12	37	300	250	350	0	4-Φ18.5	5	45	325	520	15	162	690
160L	2~8	42	110	12	37	300	250	350	0	4-Φ18.5	5	45	325	520	15	162	730
180M	2~4	48	110	14	42.5	300	250	350	0	4-Φ18.5	5	45	360	550	16	169	780
180L	4~8	48	110	14	42.5	300	250	350	0	4-Φ18.5	5	45	360	550	16	169	800
200L	2~8	55	110	16	49	350	300	400	0	4-Φ18.5	5	45	400	580	20	181	840
225S	4~8	60	140	18	53	400	350	450	0	8-Φ18.5	5	22.5	450	630	20	206	890
225M	2	55	110	16	49	400	350	450	0	8-Φ18.5	5	22.5	450	630	20	206	890
	4~8	60	140	18	53	400	350	450	0	8-Φ18.5	5	22.5	450	630	20	206	920
250M	2	60	140	18	53	500	450	550	0	8-Φ18.5	5	22.5	500	730	22	230	965
	4~8	65	140	18	58	500	450	550	0	8-Φ18.5	5	22.5	500	730	22	230	965
280S	2	65	140	18	58	500	450	550	0	8-Φ18.5	5	22.5	560	800	22	228	1040
	4~8	75	140	20	67.5	500	450	550	0	8-Φ18.5	5	22.5	560	800	22	228	1040
280M	2	65	140	18	58	500	450	550	0	8-Φ18.5	5	22.5	560	800	22	228	1090
	4~8	75	140	20	67.5	500	450	550	0	8-Φ18.5	5	22.5	560	800	22	228	1090

注: R为凸缘配合面到轴伸肩的距离 R=distance from flange to shaft shoulder.

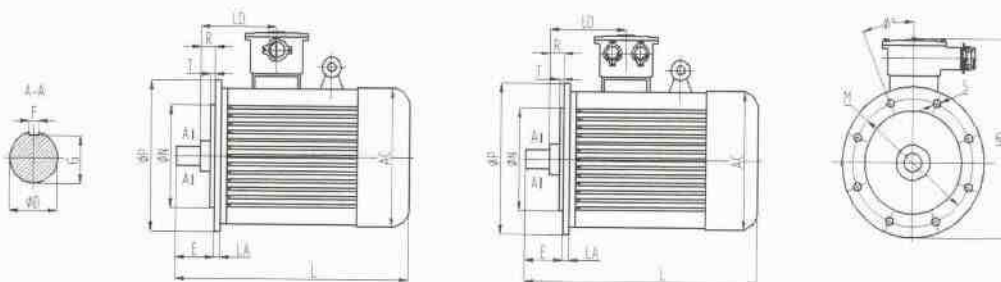

4 - VI : Vertical With flange mounted and footless (1)

机座号 Frame Size	极数 Poles	安装尺寸 Mounting Dimensions (mm)										外形尺寸 Outline Dimensions (mm)					
		D	E	F	G	M	N	P	R	S	T	Φ	AC	HD	LA	LD	L
63M	2~4	11	23	4	8.5	115	95	140	0	4-Φ10	3	45	150	230	12	78	270
	2~6	14	30	5	11	130	110	160	0	4-Φ10	3	45	155	250	12	93	300
80M	2~8	19	40	6	15.5	165	130	200	0	4-Φ12	3.5	45	170	320	12	101	345
	2~8	24	50	8	20	165	130	200	0	4-Φ12	3.5	45	190	350	12	106	400
90L	2~8	24	50	8	20	165	130	200	0	4-Φ12	3.5	45	190	350	12	106	425
	2~8	28	60	8	24	215	180	250	0	4-Φ14.5	4	45	215	400	12	102	485
112M	2~8	28	60	8	24	215	180	250	0	4-Φ14.5	4	45	230	420	14	123	550
	2~8	38	80	10	33	265	230	300	0	4-Φ14.5	4	45	270	450	15	123	585
132M	2~8	38	80	10	33	265	230	300	0	4-Φ14.5	4	45	270	450	15	123	635
	2~8	42	110	12	37	300	250	350	0	4-Φ18.5	5	45	325	520	15	162	740
160L	2~8	42	110	12	37	300	250	350	0	4-Φ18.5	5	45	325	520	15	162	780
	2~4	48	110	14	42.5	300	250	350	0	4-Φ18.5	5	45	360	550	16	169	840
180L	4~8	48	110	14	42.5	300	250	350	0	4-Φ18.5	5	45	360	550	16	169	860
	2~8	55	110	16	49	350	300	400	0	4-Φ18.5	5	45	400	580	20	181	920
225S	4~8	60	140	18	53	400	350	450	0	8-Φ18.5	5	22.5	450	630	20	206	985
	2	55	110	16	49	400	350	450	0	8-Φ18.5	5	22.5	450	630	20	206	985
225M	4~8	60	140	18	53	400	350	450	0	8-Φ18.5	5	22.5	450	630	20	206	1015
	2	60	140	18	53	500	450	550	0	8-Φ18.5	5	22.5	500	730	22	230	1060
250M	4~8	65	140	18	58	500	450	550	0	8-Φ18.5	5	22.5	500	730	22	230	1060
	2	65	140	18	58	500	450	550	0	8-Φ18.5	5	22.5	560	800	22	228	1160
280S	4~8	75	140	20	67.5	500	450	550	0	8-Φ18.5	5	22.5	560	800	26	228	1160
	2	65	140	18	58	500	450	550	0	8-Φ18.5	5	22.5	560	800	22	228	1210
280M	4~8	75	140	20	67.5	500	450	550	0	8-Φ18.5	5	22.5	560	800	26	228	1210



4 - VI : Vertical With flange mounted and footless (2)

机座号 Frame Size	极数 Poles	安装尺寸 Mounting Dimensions (mm)										外形尺寸 Outline Dimensions (mm)					
		D	E	F	G	M	N	P	R	S	T	Φ	AC	HD	LA	LD	L
315S	2	65	140	18	58	600	550	660	0	8-Φ24	6	22.5	630	1000	30	297	1335
	4~10	80	170	22	71	600	550	660	0	8-Φ24	6	22.5	630	1000	30	297	1410
315M	2	65	140	18	58	600	550	660	0	8-Φ24	6	22.5	630	1000	30	297	1455
	4~10	80	170	22	71	600	550	660	0	8-Φ24	6	22.5	630	1000	30	297	1530
315L	2	65	140	18	58	600	550	660	0	8-Φ24	6	22.5	630	1000	30	297	1455
	4~10	80	170	22	71	600	550	660	0	8-Φ24	6	22.5	630	1000	30	297	1530
355S	2	75	140	20	67.5	740	680	800	0	8-Φ24	6	22.5	720	1080	25	316	1570
	4~10	95	170	25	86	740	680	800	0	8-Φ24	6	22.5	720	1080	25	316	1640
355M	2	75	140	20	67.5	740	680	800	0	8-Φ24	6	22.5	720	1080	25	316	1650
	4~10	95	170	25	86	740	680	800	0	8-Φ24	6	22.5	720	1080	25	316	1720
355L	2	75	140	20	67.5	740	680	800	0	8-Φ24	6	22.5	720	1080	25	316	1800
	4~10	95	170	25	86	740	680	800	0	8-Φ24	6	22.5	720	1080	25	316	1830

注: R为凸缘配合面到轴伸肩的距离 R=distance from flange to shaft shoulder.

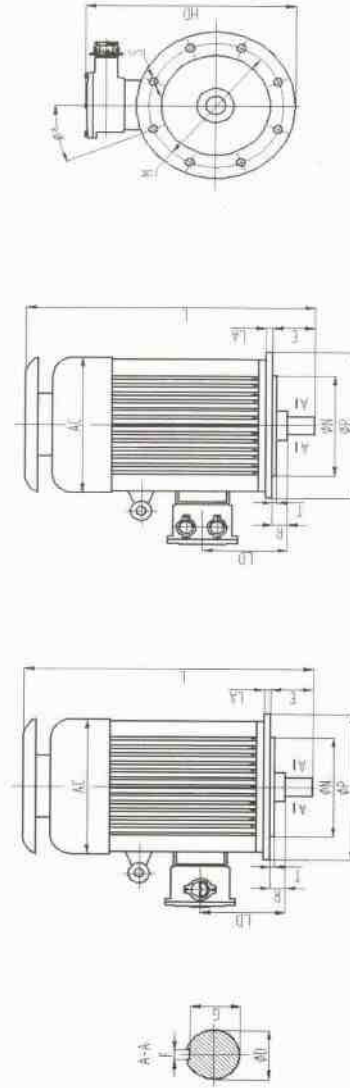



### 5 - B34 : With both foot and small flange mounted

机座号 Frame Size	极数 Poles	安装尺寸 Mounting Dimensions (mm)														外形尺寸 Outline Dimensions (mm)									
		A	B	C	D	E	F	G	H	K	M	N	P	R	S	T	AA	AB	AC	BB	BD	HA	HD	LD	L
63M	2~4	100	80	40	11	23	4	8.5	63	7	75	60	90	0	4-M5	2.5	25	130	150	110	15	8	230	78	250
71M	2~6	112	90	45	14	30	5	11	71	7	85	70	105	0	4-M6	2.5	28	140	155	114	10	8	250	93	280
80M	2~8	125	100	50	19	40	6	16	80	10	100	80	120	0	4-M6	3.0	34	165	170	130	14	10	320	101	320
90S	2~8	140	100	56	24	50	8	20	90	10	115	95	140	0	4-M8	3.0	36	180	190	130	15	14	350	106	370
90L	2~8	140	125	56	24	50	8	20	90	10	115	95	140	0	4-M8	3.0	36	180	190	155	15	14	350	106	395
100L	2~8	160	140	63	28	60	8	24	100	12	130	110	160	0	4-M8	3.5	43	200	215	176	18	14	400	102	450
112M	2~8	190	140	70	28	60	8	24	112	12	130	110	160	0	4-M8	3.5	50	245	230	180	20	16	420	123	510

注: R为凸缘配合面到轴伸肩的距离 R=distance from flange to shaft shoulder.

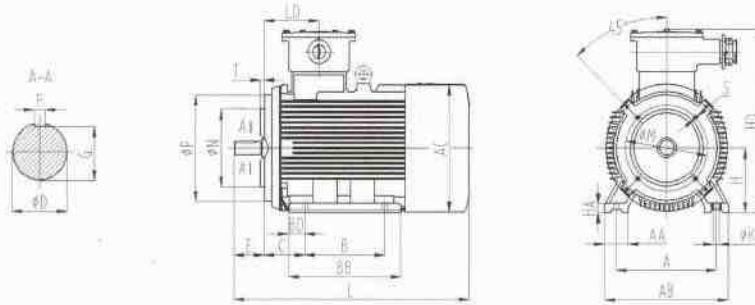

### 6 - B14 : With small flange mounted and footless

机座号 Frame Size	极数 Poles	安装尺寸 Mounting Dimensions (mm)										外形尺寸 Outline Dimensions (mm)			
		D	E	F	G	M	N	P	R	S	T	AC	HD	LD	L
63M	2~4	11	23	4	9	75	60	90	0	4-M5	2.5	150	230	78	250
71M	2~6	14	30	5	11	85	70	105	0	4-M6	2.5	155	250	93	280
80M	2~8	19	40	6	16	100	80	120	0	4-M6	3.0	170	320	101	320
90S	2~8	24	50	8	20	115	95	140	0	4-M8	3.0	190	350	106	370
90L	2~8	24	50	8	20	115	95	140	0	4-M8	3.0	190	350	106	395
100L	2~8	28	60	8	24	130	110	160	0	4-M8	3.5	215	400	102	450
112M	2~8	28	60	8	24	130	110	160	0	4-M8	3.5	230	420	123	510

注: R为凸缘配合面到轴伸肩的距离 R=distance from flange to shaft shoulder.

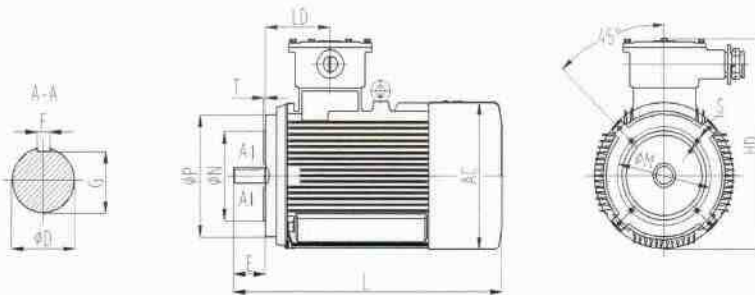

7 - YB 2-400 For the mounting and overall dimensions

**(B3) 外形及安装尺寸 DIMENSIONS**

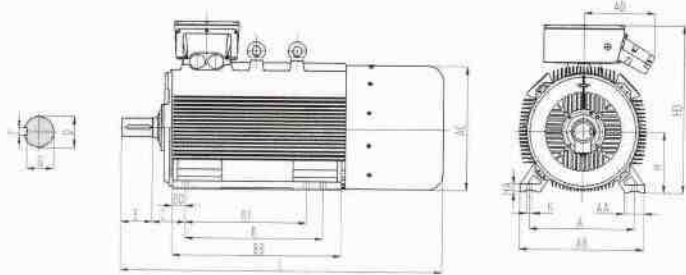

机座 Frame	极数 Poles	安装尺寸 Mounting Dimension										外形尺寸 Overall Dimension									
		A	B	B1	C	D	E	F	G	H	K	AA	AB	AC	AD	BB	BD	HD	HA	L	
400	2	686	710	630	280	85	170	22	76	400	35	120	810	850	500	1090	58	1090	45	1920	
	4~12	686	710	630	280	110	210	28	100	400	35	120	810	850	500	1090	58	1090	45	1920	

**(B35) 外形及安装尺寸 DIMENSIONS**

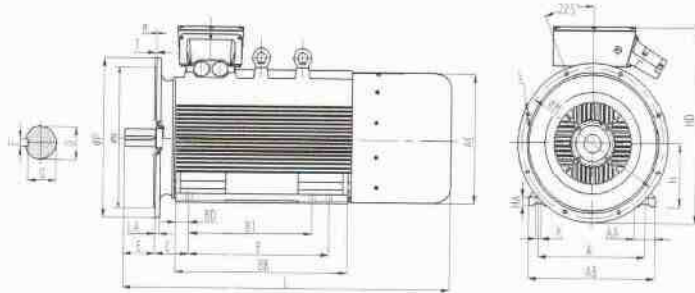

机座 Frame	极数 Poles	安装尺寸 Mounting Dimension															外形尺寸 Overall Dimension									
		A	B	B1	C	D	E	F	G	H	K	M	N	P	R	S	T	AA	AB	AC	BB	BD	HA	HD	LA	L
400	2	686	710	630	280	85	170	22	76	400	35	940	880	1000	0	8-Φ28	6	120	810	850	1090	58	45	1190	25	1920
	4~12	686	710	630	280	110	210	28	100	400	35	940	880	1000	0	8-Φ28	6	120	810	850	1090	58	45	1190	25	1920

**(V1) 外形及安装尺寸 DIMENSIONS**

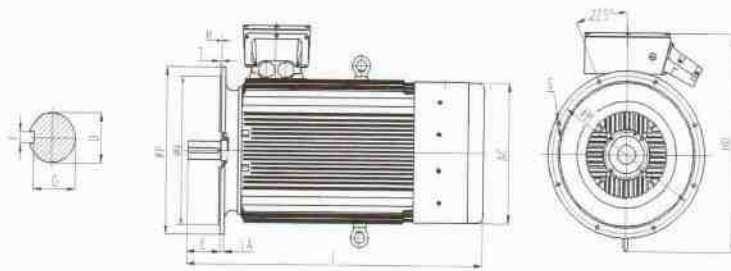

机座 Frame	极数 Poles	安装尺寸 Mounting Dimension										外形尺寸 Overall Dimension			
		D	E	F	G	M	N	P	R	S	T	AC	HD	LA	L
400	2	85	170	22	76	940	880	1000	0	8-Φ28	6	850	1280	25	1920
	4~12	110	210	28	100	940	880	1000	0	8-Φ28	6	850	1280	25	1920

## 06. Boîte à borne

机座号 Frame Size	接线螺栓直径M Terminal Screw(M)	外形尺寸 X × Y × Z (mm)
63~71	M5	Φ170 × 175 × 75
80~100	M5	Φ170 × 175 × 90
112~132	M5	Φ210 × 200 × 100
160~180	M6	Φ220 × 205 × 115
200~225	M8	Φ260 × 235 × 120
250~280	M10	Φ335 × 270 × 160
315~355	M16	Φ380 × 360 × 240
400	M16	Φ380 × 360 × 240
	M24	Φ440 × 400 × 260

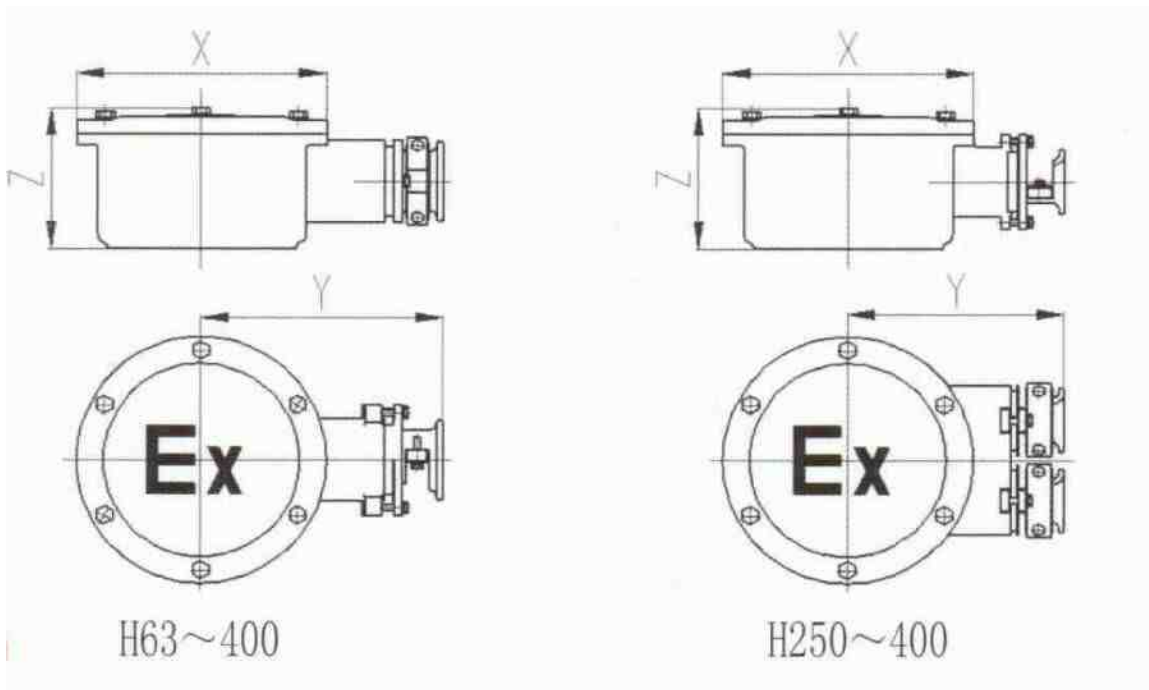

## 07. Roulements

机座号 Frame Size	轴伸端 Dirving End				非轴伸端 Non-dirving End			
	2极 (pole)	4极 (pole)	6极 (pole)	≥8极 (pole)	2极 (pole)	4极 (pole)	6极 (pole)	≥8极 (pole)
63	6201	6201	6201	6201	6201	6201	6201	6201
71	6202	6202	6202	6202	6202	6202	6202	6202
80	6204	6204	6204	6204	6204	6204	6204	6204
90	6205	6205	6205	6205	6205	6205	6205	6205
100	6206	6206	6206	6206	6206	6206	6206	6206
112	6206	6206	6206	6206	6206	6206	6206	6206
132	6208	6208	6208	6208	6208	6208	6208	6208
160	6209	6309	6309	6309	6209	6209	6209	6209
180	6211	6311	6311	6311	6211	6211	6211	6211
200	6212	6312	6312	6312	6212	6212	6212	6212
225	6312	6313	6313	6313	6312	6312	6312	6312
250	6313	6314	6314	6314	6313	6313	6313	6313
280	6314	6317	6317	6317	6314	6314	6314	6314
315	6316	NU319	NU319	NU319	6316	6319	6319	6319
355	6319	NU322	NU322	NU322	6319	6322	6322	NU322
400	6219+NU219	6226+NU226	6226+NU226	6226+NU226	NU218	NU224	NU224	NU224

